

## DESCRIPTION

The FGR Repair Kit can be used to repair Easy Heat PGE and FGG type cables severed either during installation or subsequent operation.

For the purpose of this instruction sheet, a center splice is defined as a junction between any of the following:

- Heating cable to cold lead
- Heating cable to heating cable

## TOOLS REQUIRED

Side cutters  
Crimping pliers  
Cable strippers  
Heat gun  
Needle Nose Pliers  
Knife

## METHOD

Extension wires can be used with a gap of up to 32 mm between the two severed cables. If the gap is less than 2 mm, the extension wires may not be required.

### **Extension Wires Preparation**

If extension wires are required, crimp the connectors securely onto both ends of extension wires. Refer to Fig. 1.

### **Center Splice**

(refer to Fig. 2 if you are not using extension wires and to Fig. 3 if you are using extension wires)

## KIT CONTENTS

(6) Connectors

(3) Extension wires, 32 mm

### **Heat Shrinkable Tubing:**

- A. (4) Connector heat shrink, inner, 35 mm
- B. (4) Connector heat shrink, outer, 35 mm
- C. (1) Jacket heat shrink, inner, 95 mm
- D. (1) Jacket heat shrink, outer, 95 mm

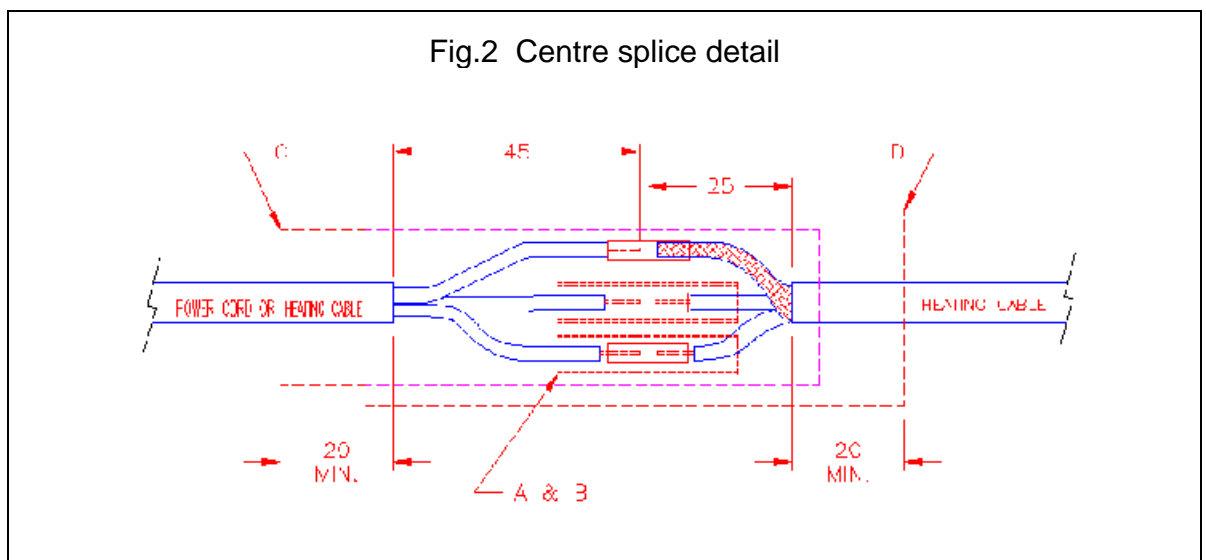
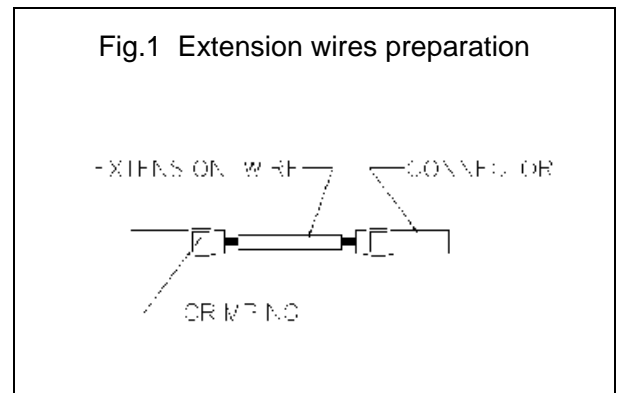

1. Remove the outer PVC jacket on each cable end and twist the heating cable's braid tightly to one side.
  2. Remove 8 mm of insulation from each conductor. For spiral heating elements use cable strippers to cut the insulation, apply heat and slightly twist clockwise to remove. Take great care not to damage the spiral.
- For stranded and solid heating elements, use cable strippers. Twist strands together.

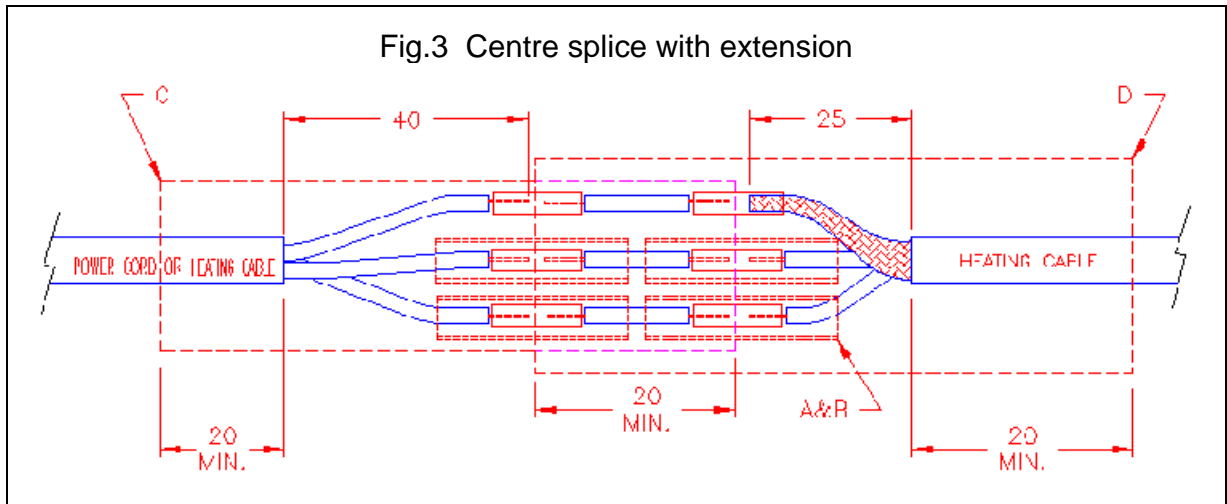

3. If extension wires are not required, go to 4. If extension wires are required crimp one end of each of the previously prepared extension wires onto conductors.
4. Slide the connector heat shrink tubings "A" and "B" over each other and then over the connector. Use one "A" and one "B" for each connector. The usage of 2 overlapped heat shrinks offers better protection. It is not required to use heat shrinks for ground connections.
5. Slide the jacket splice heat shrink "C" and "D" onto each other and then onto the cable.
6. Insert conductor into connector and compress (crimp) connector securely.
7. Repeat steps 5 and 6 for each connection.
8. Cut loose strands to ensure that they will not pierce the heat shrinks.
9. Center both (A and B) connector heat shrink over connector and apply heat. Allow the connections to cool for 20 minutes.
10. Slide jacket heat shrink over splice. Make sure to overlap "C" and "D" for about 20 mm. Apply heat.
11. Test cable for insulation resistance (500 V dc, minimum 20 MΩ) and continuity.

For the **tail splice** refer to Fig. 4. Use "C" cut to 50 mm for the connector heat shrink and "D" for the jacket heat shrink. After applying heat *squeeze* the outside end of the each heat shrink for a length of 10 mm using needle nose pliers to secure the splice.

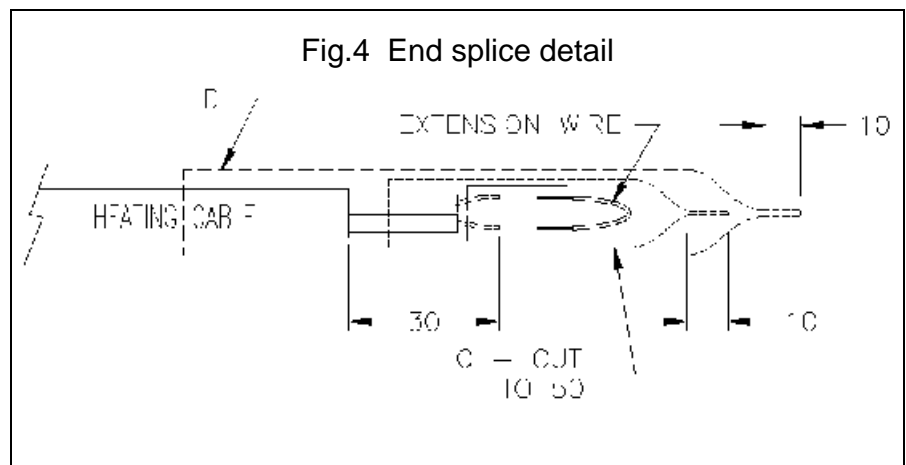

**NOTE:**

**At all time extreme care should be taken when joining cables.**

## **FGR Repair Kit**

### **Components**

<b>Name</b>	<b>PN</b>	<b>Size mm or inches</b>	<b>Number</b>	<b>Identification</b>	<b>Comments</b>
Extension Wires	10602-002	32 mm	3		
Splice connectors	16001-018		6		AMP 31818
Heat Shrink	16044-009	35 mm	4	A	
Heat Shrink	16044-019	35 mm	4	B	
Heat Shrink	16044-010	95 mm	1	C	
Heat Shrink	16044-011	95 mm	1	D	
Bag	11004-025	5X8"	1		
Label	11263-001	2.5X1"	1		
Instruction	14009-001		1		
Box	11603-005	7x5x5"	0.1		
Box Label	11264-001	2.5X1"	0.2		